



#### GENERAL DESCRIPTION

C1962 series is a CMOS analog clock integrated circuits which drives a stepping motor once every one second. It provides automatic change from variable alarm sound with crescendo to bell-motor. After 3 steps alarm sound ends, the bell-motor driving signal will output. Also it has a snooze function that restarts the alarm signal after 256 seconds.

#### FUNCTIONS

- Single 1.5V battery operation.
- 32,768Hz crystal frequency.
- Drive a stepping motor once every one second.
- Alarm sound 3 steps variable with crescendo, then automatically change to 1 step bell signal
- Snooze function triggering at low with 256 seconds interval
- ALI, SNOOZE use different pins and ALO drive speaker

#### FEATURES

- Single-chip CMOS construction.
- Low current consumption.
- Built-in chip oscillator, capacitor.
- 1 Hz stepping motor driven by the pulses with width 15.625 ms, 23.4 ms, 31.25 ms or 46.875 ms by mask option.
- 8 Hz driving motor signal
- Alarm sound autostop after 128 seconds or non-autostop by mask option.

#### PAD & PIN CONFIGURATION

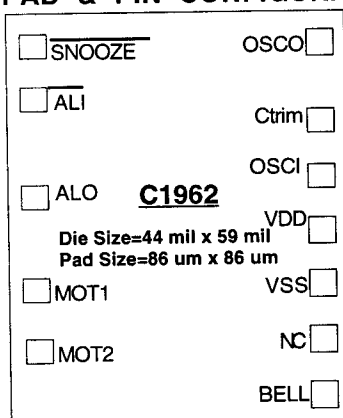

Coordinate of Each Pad

SNOOZE	(358.0, -569.0)
ALI	(358.0, -341.8)
ALO	(357.9, -92.3)
MOT1	(345.0, 125.7)
MOT2	(345.0, 284.9)
BELL	(-458.0, 480.8)
VDD	(-449.5, 170.7)
VSS	(-449.5, 15.7)
OSCI	(-458.0, -139.7)
Ctrim	(-458.0, -295.1)
OSCO	(-458.0, -574.9)

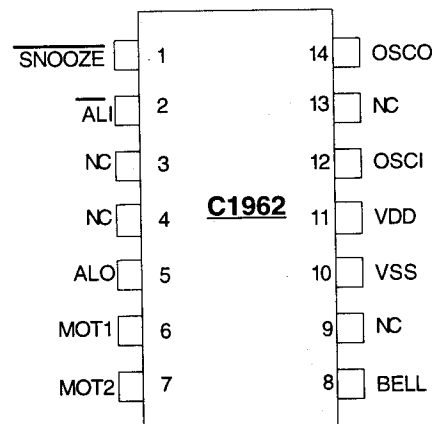

#### PAD DESCRIPTION

Pad Symbol	Function Description
$\overline{\text{SNOOZE}}$	Snooze enable input
$\overline{\text{ALI}}$	Alarm enable input
ALO	Alarm signal output to drive speaker
MOT1	Motor driving output 1
MOT2	Motor driving output 2
OSCO	32768 Hz crystal controlled oscillator
Ctrim	Built-in 0 pF Ctrim
OSCI	Built-in 24 pF OSCI
VDD	Positive power supply
VSS	Negative power supply
NC	No connection
BELL	Bell driving output

**ABSOLUTE MAXIMUM RATINGS**

Parameter	Symbol	Limits	Unit
Supply Voltage Range	VDD - VSS	-0.3 to +5.0	V
Input Voltage Range	VIN	VSS < VIN < VDD	V
Operating Temperature Range	TOPR	0 to +70	°C
Storage Temperature Range	TSTO	-55 to +150	°C

**ELECTRICAL CHARACTERISTICS**

(VDD - VSS = 1.5V, Ta = 25°C, Fosc = 32,768 Hz, X'TAL Rs = 25KΩ.)

Parameter	Symbol	Min.	Typ.	Max.	Unit	Test Conditions
Operating Voltage	VOP	1.2	1.5	1.8	V	-
Operating Current	IOP	-	1	2	μA	No Load
Saturation Resistance MOT1 - MOT2	RSR	-	50	80	Ω	VDD = 1.2V RL = 200Ω
Alarm Output Current	IALO	100	250	350	μA	VDD = 1.2V VOH = 0.7V
Alarm Frequency (Speaker)	FAS	-	2048	-	Hz	-
Stability Δ f/f	-	-	0.1	0.2	ppm	Δ VDD = 0.1V
Built-in Osc. Out Capacitance	COSCO	-	24	-	pF	-
Built-in Osc. In Capacitance	COSCI	-	24	-	pF	Bonding Option
Built-in Ctrim Capacitance	CTRIM	-	0	-	pF	-
Output Pulse Width ΔT	-	-	*15.625	-	mS	-
Oscillator Start	-	-	-	2	S	VDD = 1.2V

Notes :

1. Cin (OSC IN or Ctrim) 24 pF or 0 pF selected by bonding.
2. Stray capacitance is not included.
- \*3. Output Pulse Width is different for different options. Detail can be checked in OPTION LIST.

**ALARM WAVEFORMS**

TIME (SEC) AFTER ALARM GOES ON	ALARM WAVEFORM	DUTY (%) OF FUNDAMENTAL WAVE
0-8		12.5
9-16		25
17-24		50

**TIMING WAVEFORMS**

a. Motor output driving :

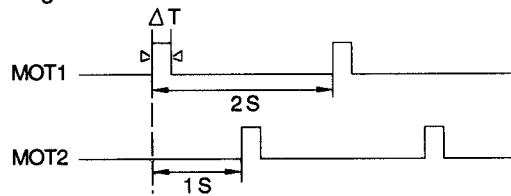

b. Motor output driving (C1962-5)

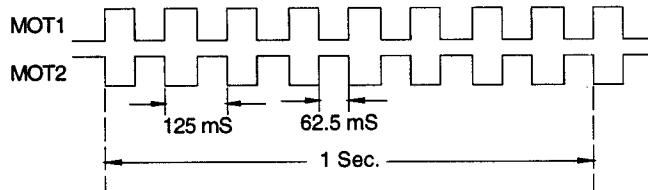

c. Bell and alarm output with snooze function when ALI and snooze use different pins :

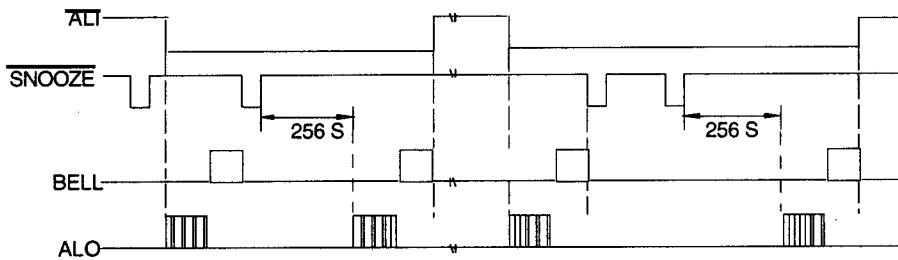

**APPLICATION CIRCUIT**

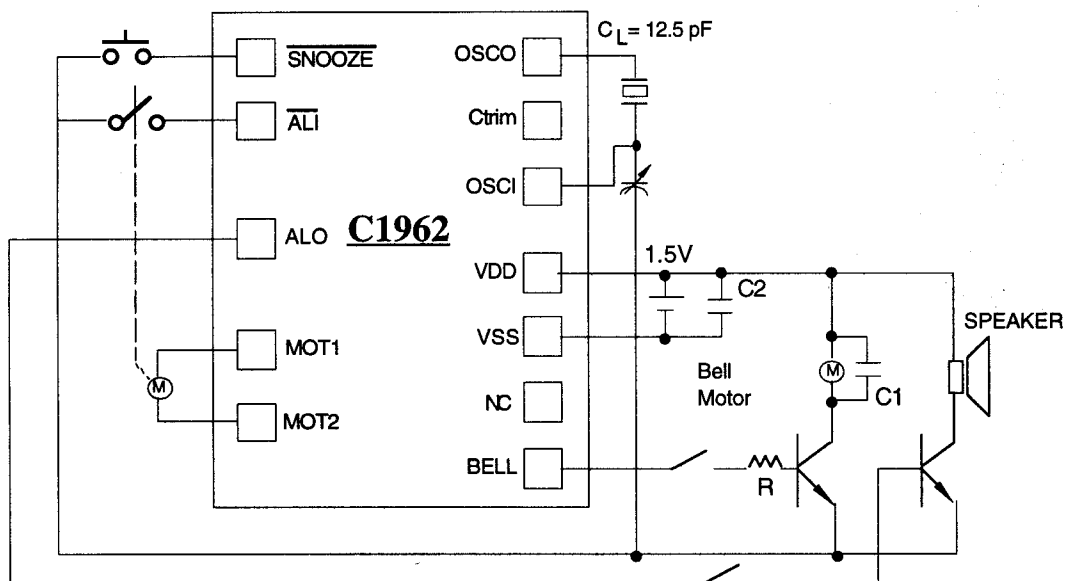

- Notes:
1.  $C1 = 10 \mu\text{F}$
  2.  $C2 > 1 \mu\text{F}$
  3.  $R = 5 \Omega$

## OPTION LIST

Device Name	Motor Pulse Width (ms)	Alarm Funtion	Device Name	Motor Pulse Width (ms)	Alarm Funtion
C1962-1	15.625	Non-stop	C1962-21	15.625	Stop after 128 s
C1962-2	23.4	Non-stop	C1962-22	23.4	Stop after 128 s
C1962-3	31.25	Non-stop	C1962-23	31.25	Stop after 128 s
C1962-4	46.875	Non-stop	C1962-24	46.875	Stop after 128 s
C1962-5	62.5	Non-stop	C1962-25	62.5	Stop after 128 s