



RCL Semiconductors Ltd.

32 KHz Analog Clock With Alarm & DC OUTPUT

C1963

GENERAL DESCRIPTION

C1963 series is a CMOS analog clock integrated circuits which drives a stepping motor once every 1/8 second. It provides a DC output and single alarm sound simultaneously, as well as a snooze function that restarts the alarm signal after 256 seconds.

FUNCTIONS

- Single 1.5V battery operation.
- 32,768Hz crystal frequency.
- Drive a stepping motor mode:
8 Hz driving motor signal with different pulse width
- Single alarm and DC output simultaneously
- Snooze function triggering at low with 256 seconds interval

FEATURES

- ALI, SNOOZE use different pins and ALO drive speaker
- Single-chip CMOS construction.
- Low current consumption.
- Built-in chip oscillator, capacitor.

PAD & PIN CONFIGURATION

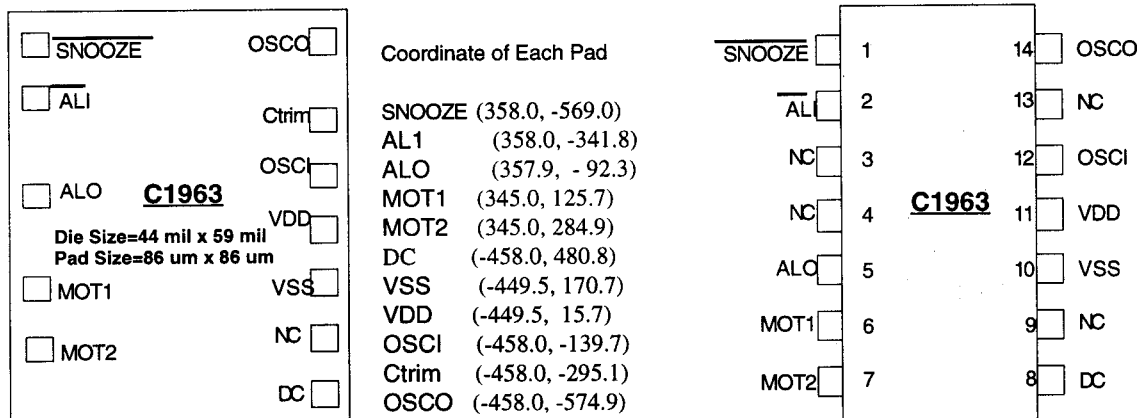

PAD DESCRIPTION

Pad Symbol	Function Description
SNOOZE	Snooze enable input
ALI	Alarm enable input
ALO	Alarm signal output to drive speaker
MOT1	Motor driving output 1
MOT2	Motor driving output 2
OSCO	32768 Hz crystal controlled oscillator
Ctrim	Built-in 0 pF Ctrim
OSCI	Built-in 24 pF OSCI
VDD	Positive power supply
VSS	Negative power supply
NC	No connection
DC	DC signal output

ABSOLUTE MAXIMUM RATINGS

Parameter	Symbol	Limits	Unit
Supply Voltage Range	VDD - VSS	-0.3 to +5.0	V
Input Voltage Range	VIN	VSS < VIN < VDD	V
Operating Temperature Range	TOPR	0 to +70	°C
Storage Temperature Range	TSTO	-55 to +150	°C

ELECTRICAL CHARACTERISTICS

(VDD - VSS = 1.5V, Ta = 25°C, Fosc = 32,768 Hz, XTAL Rs = 25KΩ.)

Parameter	Symbol	Min.	Typ.	Max.	Unit	Test Conditions
Operating Voltage	VOP	1.2	1.5	1.8	V	-
Operating Current	IOP	-	1	2	µA	No Load
Saturation Resistance MOT1 - MOT2	RSR	-	60	80	Ω	VDD = 1.2V RL = 200Ω
Alarm Output Current	IALO	100	250	350	µA	VDD = 1.2V VALOH = 0.7V
Alarm Frequency	FAS	-	2048	-	Hz	-
DC Output Current	IDC	1	1.5	-	mA	VDD = 1.3V VSSLH = 0.5V
Stability Δ f/f	-	-	0.1	0.2	ppm	Δ VDD = 0.1V
Built-in Osc. Out Capacitance	CosCO	-	24	-	pF	-
Built-in Osc. In Capacitance	CosCI	-	24	-	pF	Bonding Option
Built-in Ctrim Capacitance	CTRIM	-	0	-	pF	
Output Pulse Width ΔT	-	-	*31.25	-	mS	-
Oscillator Start	-	-	-	2	S	VDD = 1.2V

Notes :

1. Cin (OSC IN or Ctrim) 24 pF or 0 pF selected by bonding.
2. Stray capacitance is not included.
- *3. Output Pulse Width is different for different options. Detail can be checked in OPTION LIST.

ALARM WAVEFORM

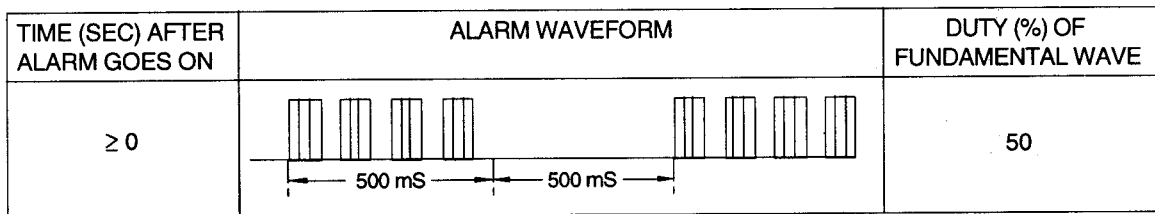

DC-OUTPUT WAVEFORM

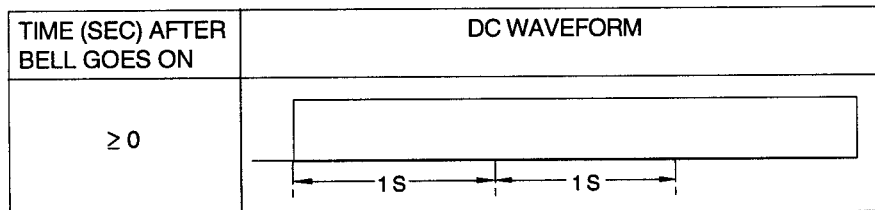

TIMING WAVEFORMS

a. Motor output driving :

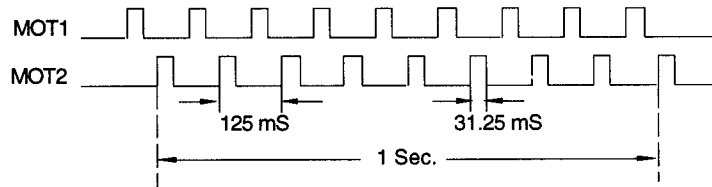

b. DC-pin and alarm outputs with snooze function when ALI and snooze use different pins :

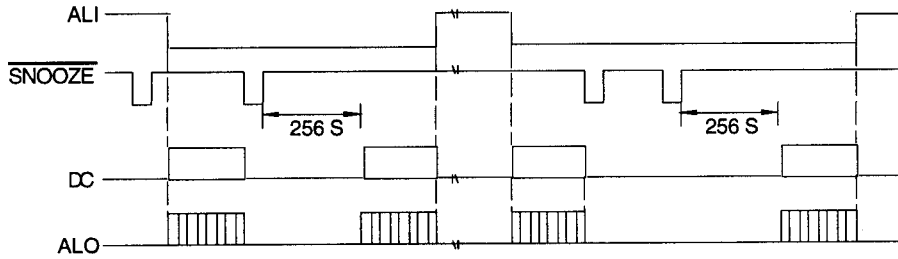

APPLICATION CIRCUIT

Application 1

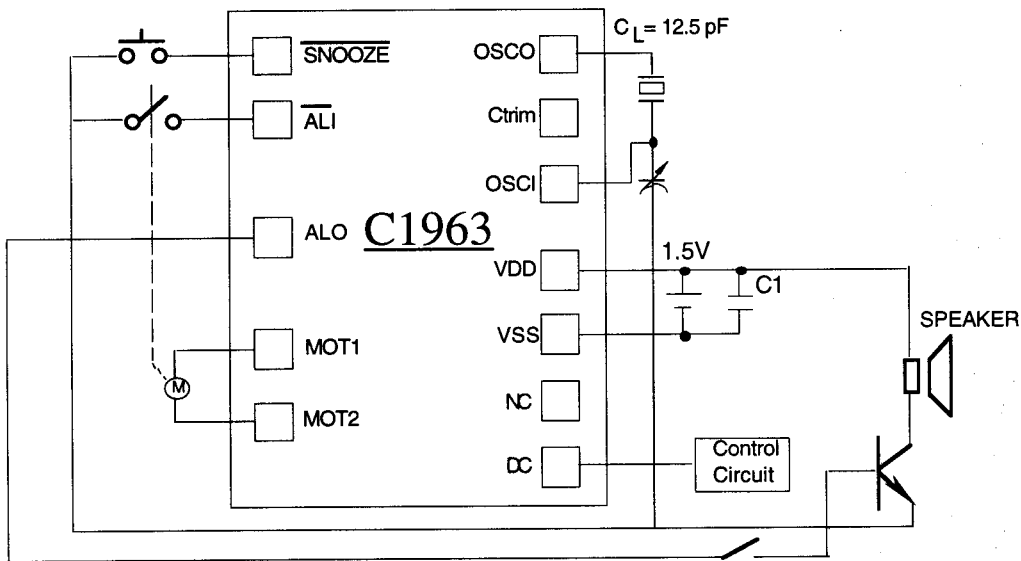

Note : C1 = 10 μ F

Application 2

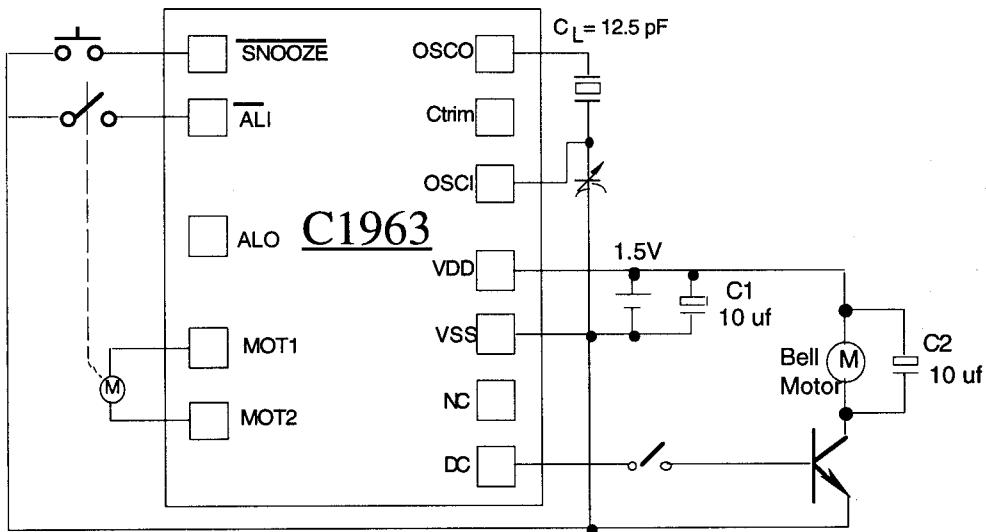

OPTION LIST

Device Name	Motor Pulse Width (ms)	Alarm Funtion	Device Name	Motor Pulse Width (ms)	Alarm Funtion
C1963-1	15.625	Non-stop	C1963-21	15.625	Stop after 128 s
C1963-2	23.4	Non-stop	C1963-22	23.4	Stop after 128 s
C1963-3	31.25	Non-stop	C1963-23	31.25	Stop after 128 s
C1963-4	46.875	Non-stop	C1963-24	46.875	Stop after 128 s
C1963-5	62.5	Non-stop	C1963-25	62.5	Stop after 128 s