

# RCL Semiconductors Ltd.

---

## 4 DIGITS COUNT DOWN TIMER

C6005

---

### GENERAL DESCRIPTION

C6005 is a four digits count-down timer CMOS LSI circuit. It can directly drive 4 digits LCD with 1/4 duty cycle and 1/2 bias. It can count down from the set-in time to zero and alarm for 64 seconds when timer reaches zero. The max. setting time is 99 minutes and 99 seconds. In addition, key tone function is selectable by bonding option.

C6005 can be widely applied in pillbox timer, kitchen timer, parking alarm timer etc..

### FUNCTIONS

- Single battery operation (1.25V - 1.7V)
- 32768 Hz quartz crystal time base
- 4 digits and two icons M & S display on LCD (with 1/4 duty cycle and 1/2 bias)
- MIN, SEC set by pressing number keys on key matrix
- Max. count down time 99 minutes 99 seconds
- After timer set, pressing START key starts counting down. Pressing STOP/RESET key pauses counting down
- After timer paused, all the number keys disable and timer reset by pressing STOP/RESET or continue counting down by pressing START
- On chip buzzer driver alarm at 2048 X 8 for up to 64 seconds when counting down reaches zero
- Alarm interrupted by pressing any key on key matrix

### FEATURES

- CMOS structure with low power consumption
- Built in voltage doubler
- Key Matrix: 0, 1, 2, 3, 4, 5, 6, 7, 8, 9, START, STOP/RESET
- Icons M and S without flashing all the time
- Special alarm output TRIG for driving another melody chip
- Special timer output TM for switch control
- All the keys debounced
- All the segments/icons and alarm sound tested
- High ESD and Latch up immunity
- Bonding option for :  
with or without key tone function;

### PIN DESCRIPTION

D1 ~ D4 - Row matrix keys

X1 ~ X3 - Column matrix keys

START - Timer start counting down control pin.

After the time set-in, the timer starts counting down when START depressed.

STOP/RESET - During count down, the timer paused when this key depressed and reset the timer when it is depressed again.

OSCI / OSCO - Oscillator Input and Output Pins

A 32768 Hz quartz crystal oscillator is connected to these two pins to generate the system timing. Both OSCI and OSCO have a built-in capacitance.

V<sub>c</sub> - Voltage doubler output

V<sub>A</sub>, V<sub>B</sub> - Voltage doubler capacitor pins

V<sub>DD</sub>, V<sub>SS</sub> - Power Supply Pins: V<sub>DD</sub> is positive power supply, V<sub>SS</sub> is ground.

COM1, COM2, COM3, COM4, A1/F1/E1, B1/G1/C1/D1, A2/F2/E2, B2/G2/C2/D2, A3/F3/E3/MS, B3/G3/C3/D3, A4/F4/E4, B4/G4/C4/D4 - LCD Display Pins:

COM1, COM2, COM3 and COM4 are backplane pins, the others are segment driving pins.

BD - Buzzer alarm driver pins. BD can drive buzzer through an external transistor.

TST1, TST2 - Test input pins. These two pins are used for speeding up the wafer test during production.

OPT - Bonding option for touch tone function. When OPT is floating or connected to Vdd, the touch tone function is enable and 62.5 ms signal is sounded when any key is depressed; when it is connected to Vss, this function is disable.

TRIG - Trigger output

When count down reaches zero, TRIG pin sends out a high level signal last for 64 seconds. When alarm sound stops or any key is depressed, it will go back to low level.

TM - During count down, it is high and when count down stops it goes to low.

**FUNCTIONAL DESCRIPTION**

- a. When power on timer, LCD will display  $\square\square^M\square\square^S$ .
- b. Timer is set by pressing number keys on key matrix and the numbers will shift in sequence from low to high digit. The numbers above four entered from the key matrix will have no effect on LCD display. Timer setting is effective only when LCD displays  $\square\square^M\square\square^S$ .
- c. After timer has been set, pressing START key will start counting down.
- d. During counting down, pressing STOP/RESET key will pause counting down and the timer can not be set at this moment. It will continue counting down from the paused value when pressing START key.
- e. The timer will reset to  $\square\square^M\square\square^S$  by pressing STOP/RESET key when counting down is paused.
- f. When counting down to zero, LCD will display  $\square\square^M\square\square^S$  and buzzer will alarm out 2048 X 8 X1 Hz signal for 64 seconds. During this alarm period, any key on key matrix depressed will interrupt the alarm sound.

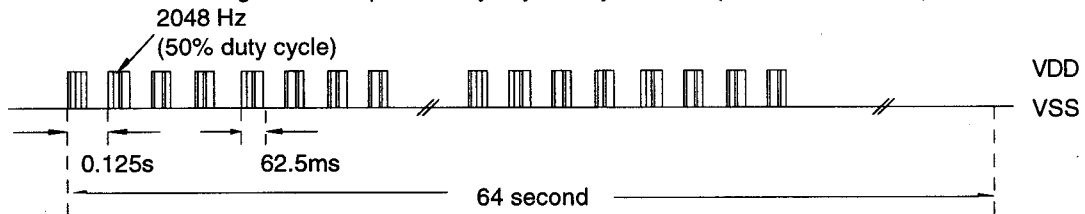

g. Waveform of touch tone function:

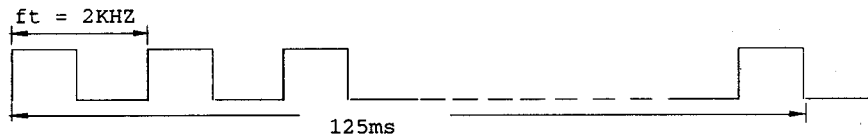

**LCD FORMAT**

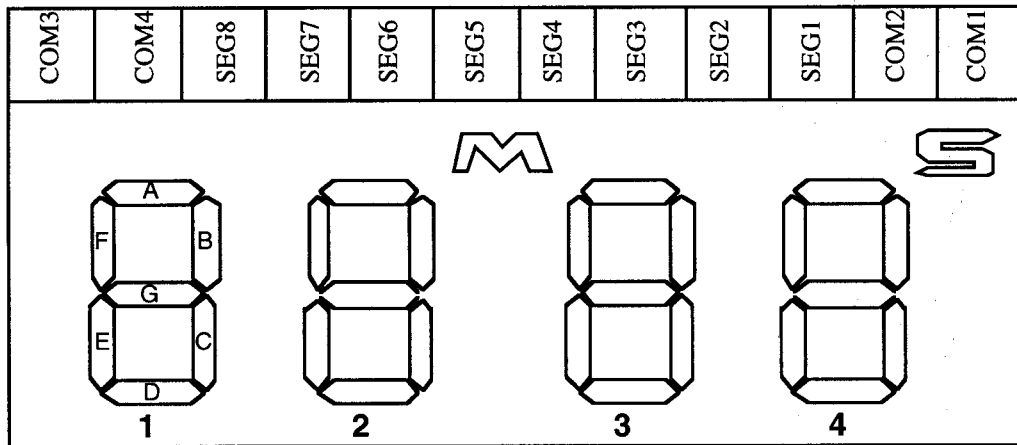

Pad NO. in IC	12	11	10	9	8	7	6	5	4	3	2	1
			SEG8	SEG7	SEG6	SEG5	SEG4	SEG3	SEG2	SEG1		
COM1			A1	B1	A2	B2	A3	B3	A4	B4		COM1
COM2			F1	G1	F2	G2	F3	G3	F4	G4	COM2	
COM3	COM3		E1	C1	E2	C2	E3	C3	E4	C4		
COM4		COM4		D1		D2	M, S	D3		D4		

RCL reserves the right to make changes to these specifications at any time without notice, and RCL does not assume any responsibility for use of any circuitry described

**ABSOLUTE MAXIMUM RATINGS (Ta = 25 °C)**

Parameter	Symbol	Limits
Power supply voltage range	Vss - VDD	-0.3 V to +5.0V
Input voltage range	Vin	Vss -0.3 to VDD +0.3
Operating temperature range	TA	-10 to +60°C
Storage temperature range	Tstg	-40 to +70°C

**DC ELECTRICAL CHARACTERISTICS**

Unless otherwise specified, Ta = 25°C, VDD = 1.5V, Vss = 0V, Fosc = 32768 Hz

Characteristics	Symbol	Min.	Typ.	Max.	Unit	Test Conditions
Operating voltage range	VDD	1.25	1.5	1.7	V	-
Doubler Output Voltage	Vc	2.4	3.0	3.6	V	-
Supply current	Icc	-	1.5	3.0	μA	LCD is off (Vdd=1.3V)
LCD Display Frequency	Fd	-	64	-	Hz	Vdd=1.3V while LCD is on
Alarm Output Frequency	FBD	-	2048x8	-	Hz	-
Alarm & TM & TRIG	IOL	0.3	-	-	MA	VOL=0.15V TM & TRIG output
Output Low Drive Current		5	10	-		VOL=0.5V BD output
Output high Drive Current	IOH	-0.3	-	-	MA	VOH=1.35V TM & TRIG output
Oscillator Built-in Capacitor	CD	-	20	-	pF	-
Oscillator Start up Time	Tosc	-	-	3	sec	VDD= 1.3V

PAD DIAGRAM

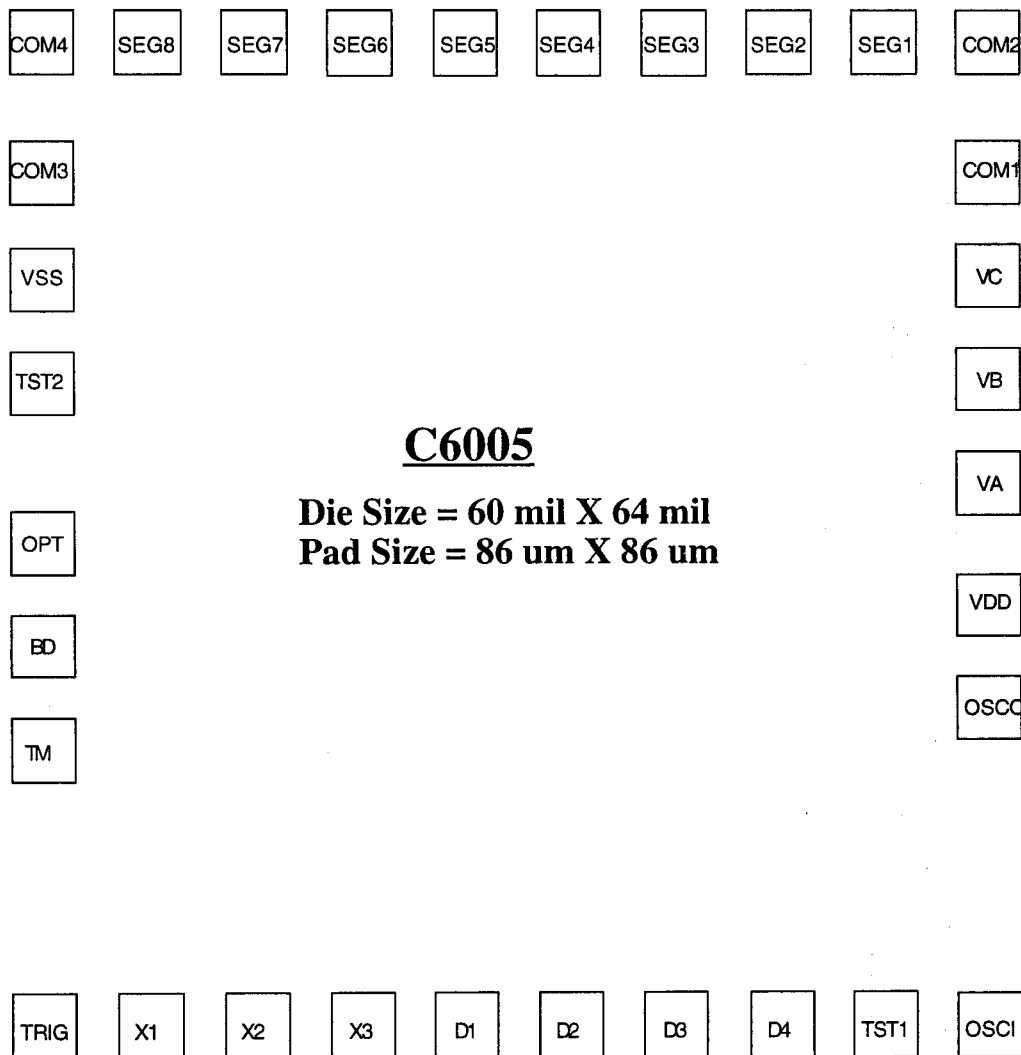

**The Co-ordinate for Low Left Corner of Each Pad**

TRIG (-677.5, -712.4)	OSCO (591.5, -278.4)	SEG1 (450.5, 626.3)	COM3 (-677.5, 451.9)
X1 (-536.5, -712.4)	VDD (591.5, -137.2)	SEG2 (309.5, 626.3)	VSS (-677.5, 306.1)
X2 (-395.5, -712.4)	VA (591.5, 28.8)	SEG3 (168.5, 626.3)	TST2 (-677.5, 165.1)
X3 (-254.5, -712.4)	VB (591.5, 169.8)	SEG4 ( 27.5, 626.3)	OPT (-677.5, - 49.5)
D1 (-113.5, -712.4)	VC (591.5, 310.8)	SEG5 (-113.5, 626.3)	BD (-677.5, -191.3)
D2 ( 27.5, -712.4)	COM1(591.5, 451.9)	SEG6 (-254.5, 626.3)	TM (-677.5, -332.3)
D3 ( 168.5, -712.4)	COM2(591.5, 626.3)	SEG7 (-395.5, 626.3)	
D4 ( 309.5, -712.4)		SEG8 (-536.5, 626.3)	
TST1 ( 450.5, -712.4)		COM4(-677.5, 626.3)	
OSCI ( 591.5, -712.4)			

APPLICATION CIRCUIT

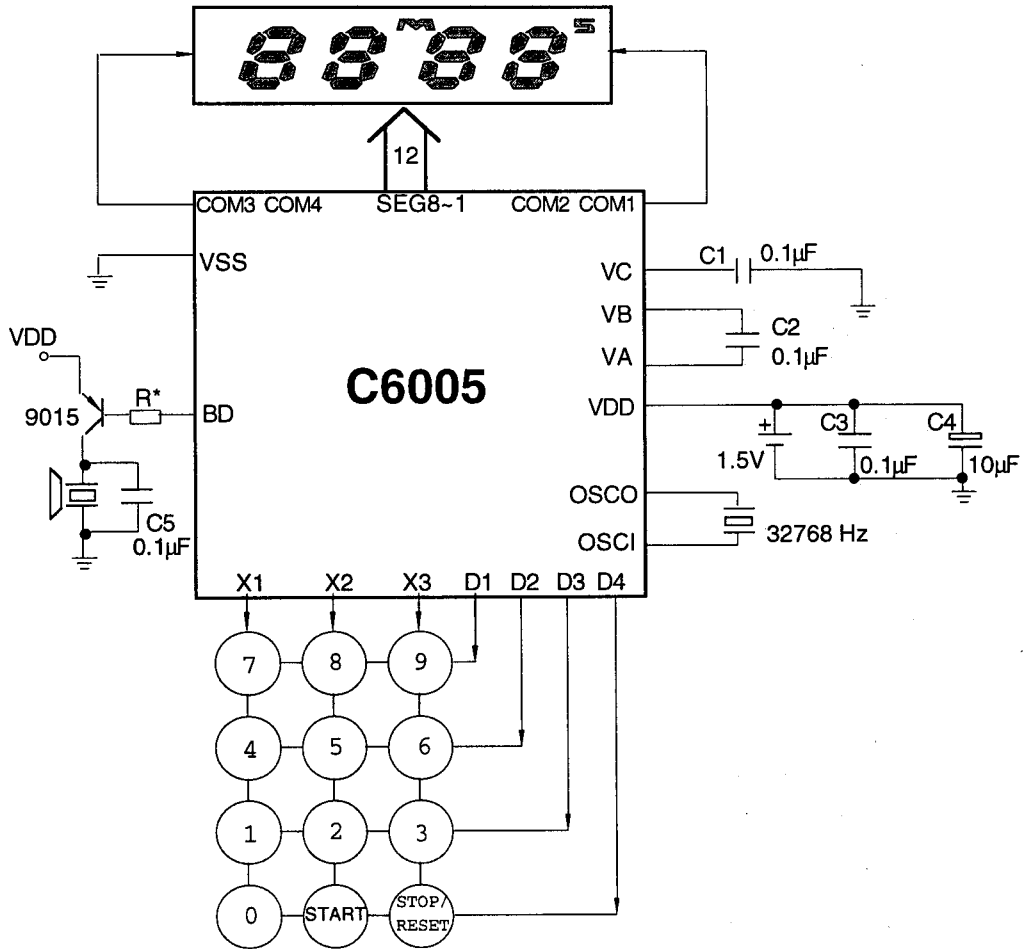

**Note:** Substrate must be connected to Vss.