



GENERAL DESCRIPTION

C9718 is a CMOS LSI calculator chip with 8 digits arithmetic operations, one accumulating memory and one special memory which can retent the content after power off, two country currency exchange (C1, C2) and exchange rate setting (SET), percentage and extraction-of-square-root calculations, designed for triplex LCD application with either 1.5V battery or solar cell power supply.

FUNCTIONS

- Two country currency exchange (C1, C2).
- Currency exchange rate setting (SET).
- Four standard functions (+, -, x, ÷).
- Auto-constant calculations (constant : multiplicand, divisor, addend and subtrahend).
- Mark-up and mark-down calculations.
- Extraction of square root.
- Percentage calculations.
- Chain multiplication and division.

FUNCTIONAL DESCRIPTION

a. Floating point system

- 8 digits floating decimal point system, with leading zero suppression, Zero shift.
- Symbols : '-' Negative number indicator.
: 'E' Error status indicator.
: 'M' Non-zero memory indicator.
: '9' Punctuation comma.
: 'SET' Exchange rate setting indicator.
: 'C1', 'C2' Country currency indicator.

b. Error Detections

- System errors occur when :
 - The integral part of any calculation result exceeds 8 digits.
 - The integral part of any memory calculation result exceeds 8 digits.
 - The integral part of any addend or subtrahend to memory exceed 8 digits.
 - The integral part of a mark-up or mark-down calculation result exceeds 8 digits.
 - The division by zero.
 - The extraction of square root of a negative number.
- Rough estimate calculation error

APPLICATION

This specification contains complete informations of functional operations, electrical characteristics, packaging, and crating requirements of C9718.

FEATURES

- Accumulating memory : M+, M-, RM, CM, MRC
- Special memory which can retent the content after power off.
- Floating decimal.
- Overflow indication : E.
- Automatic power off function.
- Punctuation comma display.

- The integral part of the result of any standard functions, percentage, square, reciprocal or power calculations exceeds 8 digits

c. Error Indication

i) System error

'0' is indicated in the 1-digit position and 'E' in the sign indicator position.

ii) Rough estimate calculation error

The high-order 8 digits of a calculation result is indicated together with 'E'. The decimal point is indicated in the position corresponding to a calculation result times 10^{-8} , and no zero shift is performed.

d. Error Release

i) System error can be released by the ON/C key.

ii) Rough estimate calculation error can be released by the ON/C, CE key.

e. Number Entry

Numerical can be entered up to 8 digits, entries that equal to 9 digits or more will be ignored.

f. Memory Protection

The memory contents before any error detection are protected.

g. Memory Indication

If the memory contents is non-zero, 'M' is indicated in the memory indicator position.

h. Double Key Depression

The order of priority when two keys are being depressed simultaneously is as follows :

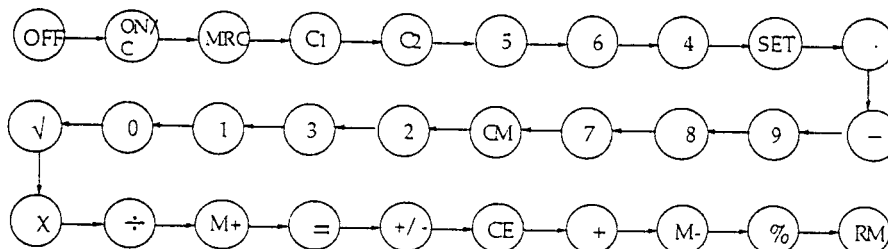

When the OFF and ON/C key are depressed simultaneously, the OFF key is given priority.

i. Key bounce protection

i) Front edge : down to 1 word and up to about 3 words.

ii) Trailing edge : 9 words. (1 word is 3.3ms when display frequency is $F_d=100\text{Hz}$.)

j. Auto Power Off

Power automatically turns off after 9 - 11 minutes pass from the last key press, but the power supply for special memory will still be on unless the battery is removed.

k. Clear Operation

All operations except memory content are cleared by ON/C key.

l. Exchange Rate Setting

The exchange rate can be set and put in special memory by pressing "SET" key after numerical entries, the content in special memory may not be changed until another number is set in. The content (exchange rate) is retained even when power off.

The "SET" icon will shows up when pressing "SET" key after numerical entries and will not disappear until any other key pressed.

m. Currency exchange

Numerical entries ended with "C1" will display the result of the entered number multiplying the exchange rate which has set and put in special memory.

Numerical entries ended with "C2" will display the result of the entered number dividing the exchange rate which has been set and put in special memory.

n. Exchange Rate Display

Pressing "1" and "C1" will display the exchange rate which has been put in special memory.

ABSOLUTE MAXIMUM RATINGS

Parameters	Symbol	Value	Unit	Note
Extremely voltage	VDD	- 0.3 ~ + 2.0	V	1
	VIN	- 0.3 ~ VDD + 0.3	V	1
Solar Supply Voltage	VSB	1.1 ~ 3.0	V	2
	VGG (LIM)	1.1 ~ 1.8	V	3
Operating temperature range	TOPR	0 ~ + 50	°C	--
Storage temperature range	TSTG	- 55 ~ + 125	°C	--

Note 1 : Maximum voltage on any pin is referenced to GND.

Note 2 : VSB is solar supply voltage.

Note 3 : VGG (lim) is limited voltage.

ELECTRICAL CHARACTERISTICS

(Ta = 25°C, VDD = 1.5V unless otherwise specified)

Parameter	Symbol	Min.	Typ.	Max.	Unit	Test Condition	Note
Input Voltage	VIH	VDD-0.4	--	--	V	--	4
	VIL	--	--	0.4	V	--	
Input Current	IiH	--	--	1	μA	VIN = VDD	5
	IiL	0.3	1	3	μA	VIN = 0V	
Output Voltage 1	VOH	VDD-0.15	--	--	V	No load	6
	VOL	--	--	0.15	V	IOUT = 15μA	
Output Voltage 2	VOA	2.8	2.95	--	V	No load	7
	VOB	1.3	1.5	1.7	V	No load	
	VOC	--	0	0.2	V	No load	
Display Frequency	Fd	40	55	65	Hz	VDD = 1.3V while display is ON.	7
Dissipation Current	Ioff	--	--	0.1	μA	Display is OFF	8
	IDIS	--	4.2	6	μA	VDD = 1.3V while display is on.	9
	IOP	--	6.8	--	μA	VDD = 1.1V, while operation.	10

Note 4 : Applies to Pins K2 ~ K6.

Note 5 : Applies to Pins K2 ~ K6.

Note 6 : Applies to P1, P2, A2X ~ A5X.

Note 7 : Applies to H1 ~ H3, A1 ~ A8, B1 ~ B8, C1 ~ C8.

Note 8 : Measured by the test circuit below after power supply automatically turns off.

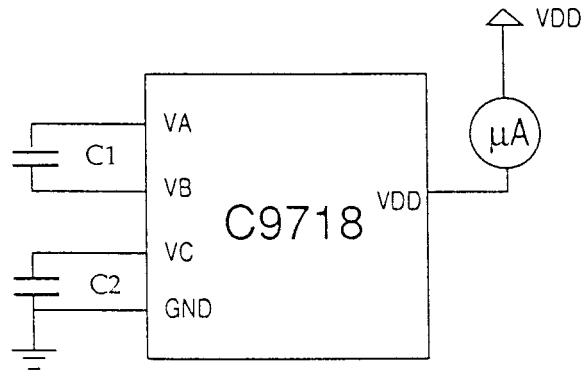

Note 9 : Measured by the test circuit while "0" is being displayed after auto - clear operation and while key is not being depressed.

Note 10 : Measured by the test circuit while operation is being made by ON/C key and while key is not being depressed.

LCD BACKPLANE OUTPUT WAVEFORM

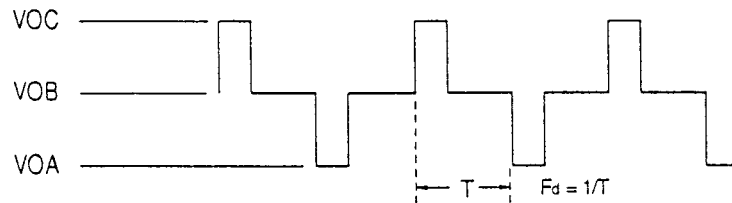

DISPLAY FONTS

a. Numerical Font

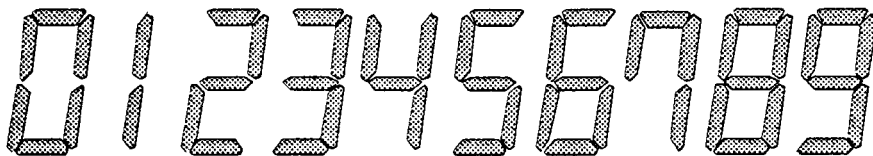

b. Sign Font



LCD CONNECTOR

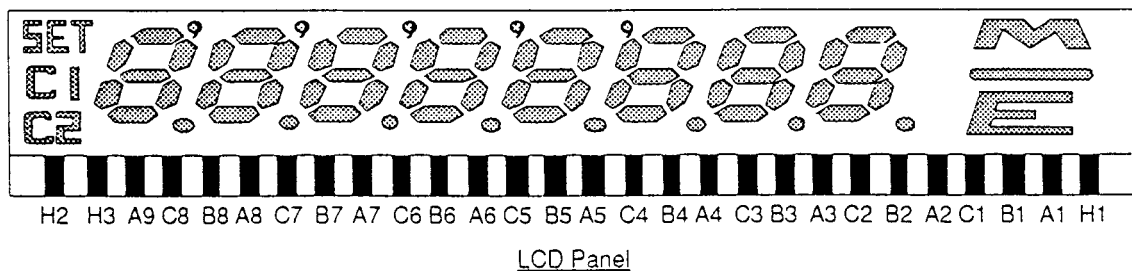

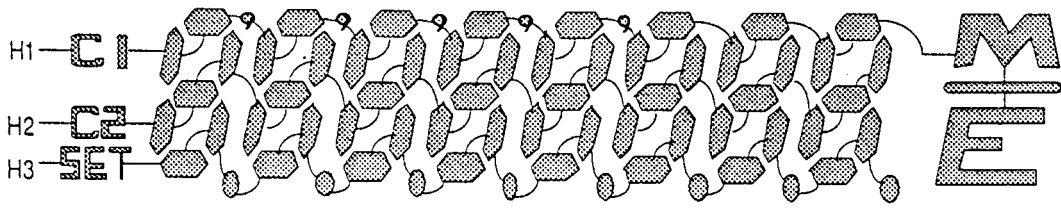

Backplanes Connection

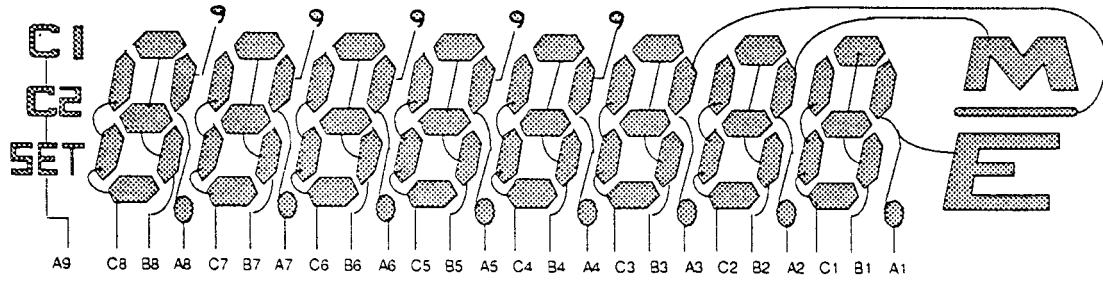

Segment Connection

PIN DESCRIPTION

Pin No.	Signal	I/O	Description	Pin No.	Signal	I/O	Description
1	VSB	1	Solary Battery	25	B7	O	Display output.
2	Vop	1	Option Pin	26	C7	O	Display output.
3	VDD		Power supply.	27	A8	O	Display output.
4	H1	O	Display output.	28	B8	O	Display output.
5	A1	O	Display output.	29	C8	O	Display output.
6	B1	O	Display output.	30	A9	O	Display output.
7	GND		Ground.	31	H2	O	Display output.
8	C1	O	Display output.	32	H3	O	Display output.
9	A2	O	Display output.	33	GND		Ground.
10	B2	O	Display output.	34	VC	O	Cap terminal for voltage step-up.
11	C2	O	Display output.	35	VA	O	Cap terminal for voltage step-up.
12	A3	O	Display output.	36	VB	O	Cap terminal for voltage step-up.
13	B3	O	Display output.	37	CGin	I	Input terminal for CG.
14	C3	O	Display output.	38	K3	I	Key input.
15	A4	O	Display output.	39	K2	I	Key input.
16	B4	O	Display output.	40	A2X	O	Strobe output.
17	C4	O	Display output.	41	A3X	O	Strobe output.
18	A5	O	Display output.	42	A4X	O	Strobe output.
19	B5	O	Display output.	43	A5X	O	Strobe output.
20	C5	O	Display output.	44	P2	O	Strobe output.
21	A6	O	Display output.	45	P1	O	Strobe output.
22	B6	O	Display output.	46	K5	I	Key input.
23	C6	O	Display output.	47	K6	I	Key input.
24	A7	O	Display output.	48	K4	I	Key input.

PAD DIAGRAM

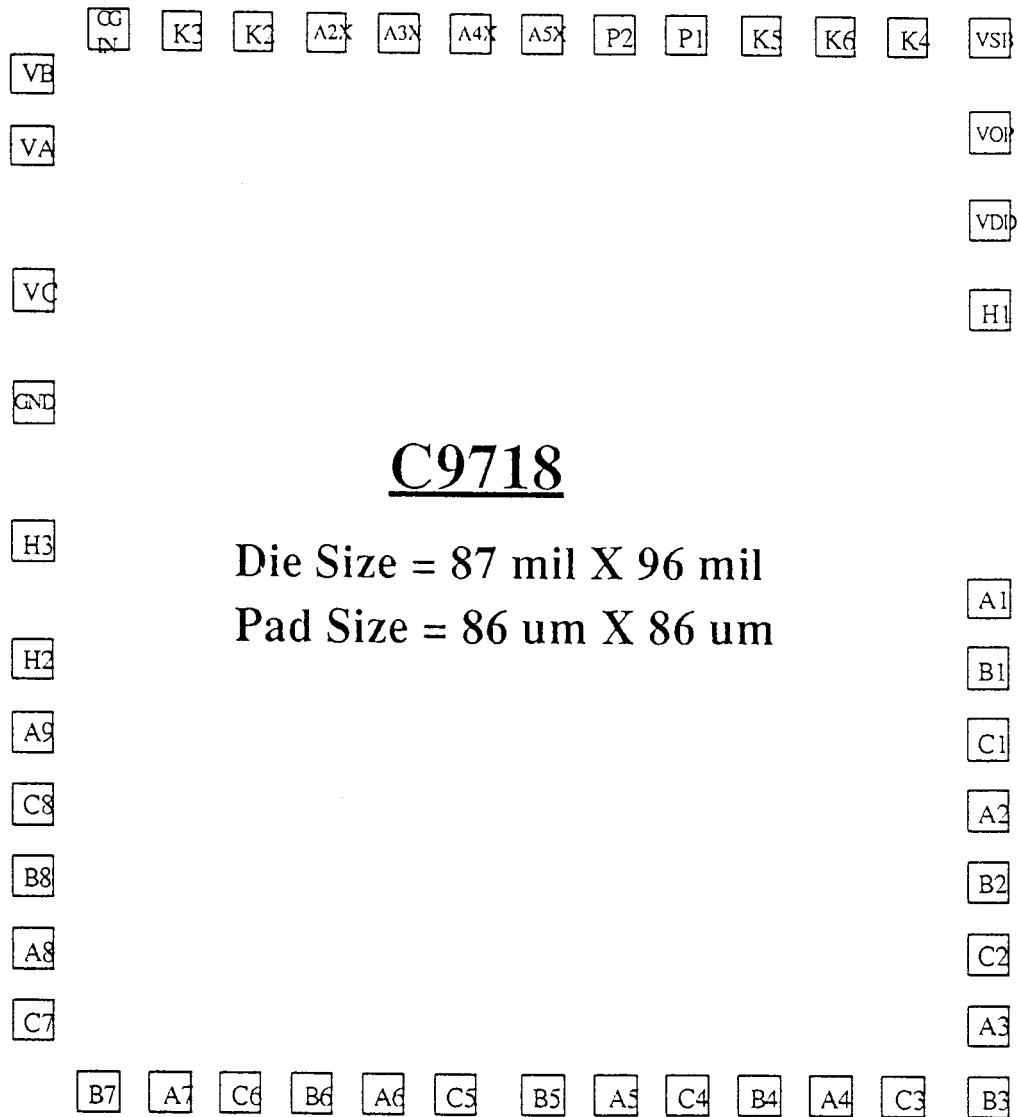

The Co-ordiante For Low Left Corner of Each Pad

B7(-885.5, -1127.8)	A3 (932.0, -981.7)	K4 (766.0, 1043.7)	VB (-1016.9, 949.3)
A7(-739.3, -1127.8)	C2 (932.0, -835.3)	K6 (618.6, 1043.7)	VA (-1016.9, 803.0)
C6(-593.3, -1127.8)	B2 (932.0, -689.0)	K5 (471.1, 1043.8)	VC (-1016.8, 508.4)
B6(-447.2, -1127.8)	A2 (932.0, -542.6)	P1 (317.8, 1043.8)	GND(-1016.9, 279.6)
A6(-301.1, -1127.8)	C1 (932.0, -396.4)	P2 (170.8, 1043.8)	H3 (-1016.9, - 5.6)
C5(-154.8, -1127.8)	B1 (932.0, -250.3)	A5X (23.8, 1043.8)	H2 (-1019.0, -245.8)
B5(24.1, -1127.8)	A1 (932.0, 105.4)	A4X (-123.1, 1043.7)	A9 (-1019.0, -393.9)
A5(170.4, -1127.8)	H1 (935.0, 486.8)	A3X (-270.2, 1043.7)	C8 (-1019.0, -541.9)
C4(316.7, -1127.8)	VDD(935.0, 670.1)	A2X (-417.2, 1043.8)	B8 (-1019.0, -688.0)
B4(463.1, -1127.8)	VOP (935.0, 845.3)	K2 (-567.3, 1043.7)	A8 (-1019.0, -834.3)
A4(609.3, -1127.8)	VSB(935.1, 1043.9)	K3 (-714.2, 1043.7)	C7 (-1019.0, -980.4)
C3(755.7, -1127.8)		CGIN(-861.3, 1043.7)	
B3(932.0, -1127.8)			

APPLCIATION DIAGRAM WITH SOLAR CELL SUPPLY

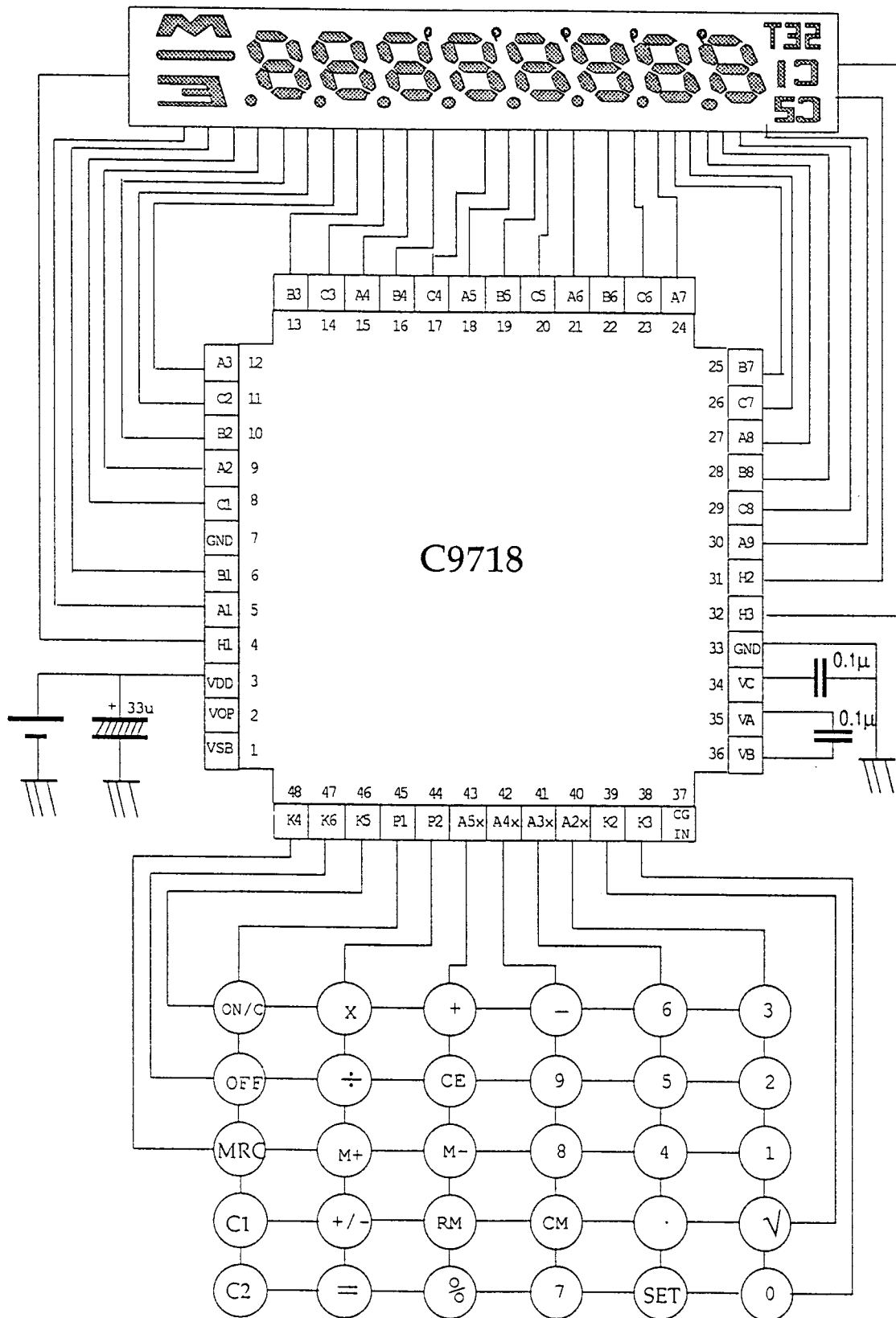

Note : Chip substract must be flooting or connected to GND.

APPLCIATION DIAGRAM WITH BATTERY SUPPLY

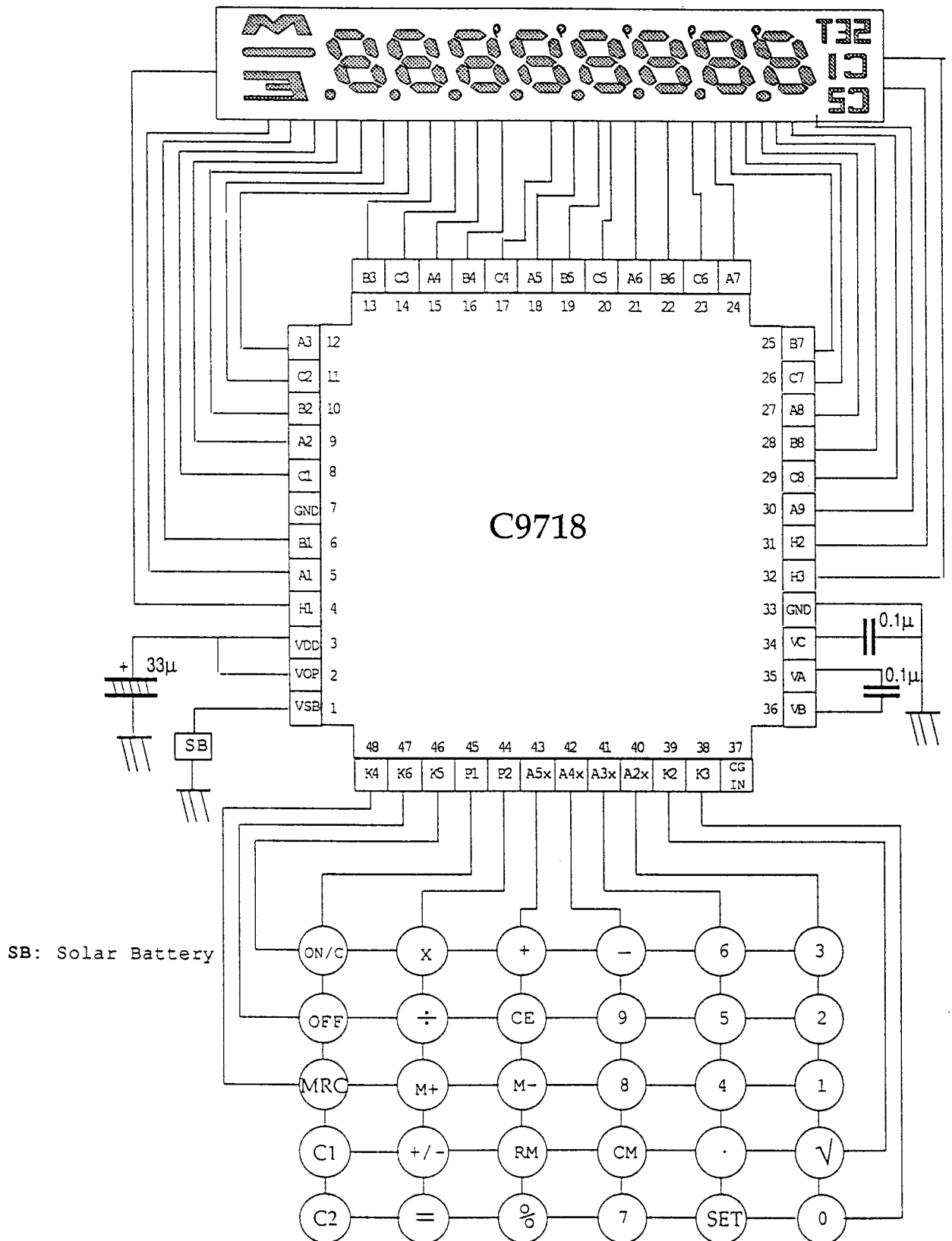

Note : Chip substract must be floating or connected to GND.